

PNEUMATRON

www.pneumatron.co.za

sales01@pneumatron.co.za

PVX2XXW Series

ELECTRIC MOTOR - 2/2 Way STAINLESS BALL VALVE

SPECIFICATIONS:

Media: Compatible media with Stainelss Steel, PTFE & EPDM.

Ambient temperature: Minus 15 to 50 Deg C

Media temperature: 2 to 95 Degrees C

Voltages: 9/24 VDC and 110/230VAC

(Below 1" Tests was done with 24VDC Item-9-26VDC)

Lower Voltage applied, Lowers Speed of movement.

(24VDC Still works at 3V , but slower)

(Cable Lenght 500 mm)



PLEASE NOTE FOR ALL AUTO CLOSE VALVES:

Ball valve are not suitable for high frequency cycle rates, maximum 6 cycles per hour.

For ball valves sizes 1/2", 3/4" & 1" the minimum open time for Normally Closed (PVC) valves is 1 to 3 minutes, minimum close time for Normally Open (PVO) valves is 1 to 3 minutes.

1/4" (8mm), 1/2" (15mm), 3/4" (20mm) & 1" (25mm) close and open in +/- 3 seconds

For ball valves sizes 1 1/2" & 2" the minimum open time for Normally Closed (PVC) valves is 5 minutes, minimum close time for Normally Open (PVO) valves is 5 minutes.

1 1/4" (32mm), 1 1/2" (40mm) & 2" (50mm) close and open +/- 10 seconds

Port & Orifice Size	Pressure Range	Wiring Diagram	Body
1/2" BSP (15 mm)	0 to 10 Bar	See page 2/3	PVX215WXXDX
3/4" BSP (20 mm)	0 to 10 Bar	See page 2/3	PVX220WXXDX
1" BSP (25 mm)	0 to 10 Bar	See page 2/3	PVX225WXXDX
1 1/2" BSP (40mm)	0 to 10 Bar	See page 2/3	PVX240WXXDX
2" BSP (50 mm)	0 to 10 Bar	See page 2/3	PVX250WXXDX

Wiring options:

Please refer to page 2/3 or phone/email us for assistance.

PVX - PVC=Normally/Fail Closed, PVO=Normally/Fail Open, PVD=Detend (Depends on wiring)

WXX - Describes wiring type page 2/3 (typically W22 or W31...)

DX - Describes voltage (D1=AC110-220V, D2=AC/DC9-24V)

The following diagram is a sample test to show speed comparisons at different voltages

PVX TEST ELECTRICAL SPECIFICATION (1" Valve- 24VDC-W31 Spec)			
VOLTAGE	CURRENT		OPEN/CLOSE TIME
9.0 VDC	+15 mA		+ 9.0 seconds
12 VDC	+18 mA		+ 6.0 seconds
15 VDC	+20 mA		+ 5.2 seconds
24 VDC	+23 mA		+ 3.7 seconds
26 VDC	+28 mA		+ 2.9 seconds

PNEUMATRON

www.pneumatron.co.za

sales01@pneumatron.co.za

Wiring diagrams

W22 (2 Wire control - Spring return)

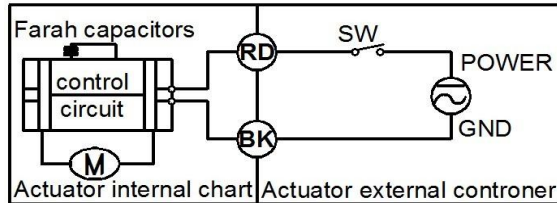

SW is closed, the valve opens. Actuator switches off automatically when ball valve is completely open.

SW is open, the valve closes. Actuator switches off automatically when ball valve is completely closed.

W52 (With feedback signal)

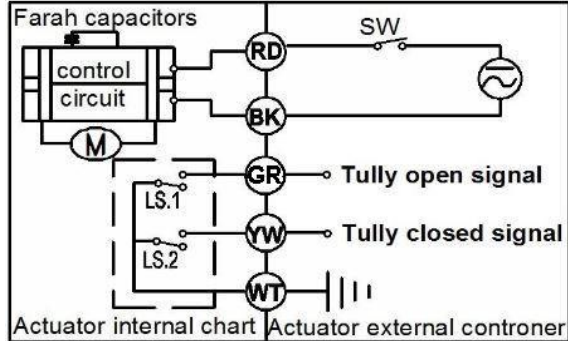

SW is closed, the valve opens. Actuator switches off automatically when ball valve is completely open.

SW is open, the valve closes. Actuator switches off automatically when ball valve is completely closed.

GR & WT connects to signal when the valve is fully open.

YW & WT connects to signal when the valve is fully closed.

W31 (3 Wire control)

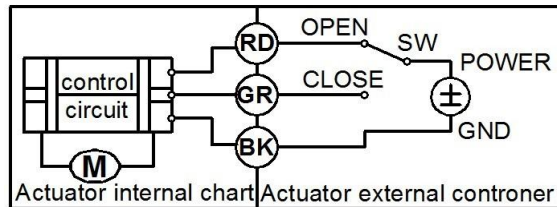

RD & GR connects to positive, BK connects to negative

When RD & SW are connected, the valve opens. Actuator switches off automatically when ball valve is completely open. Valve remains in open position

When GR & SW are connected, the valve closes. Actuator switches off automatically when ball valve is completely closed. Valve remains in closed position.

W72 (7 Wire control with feedback signal)

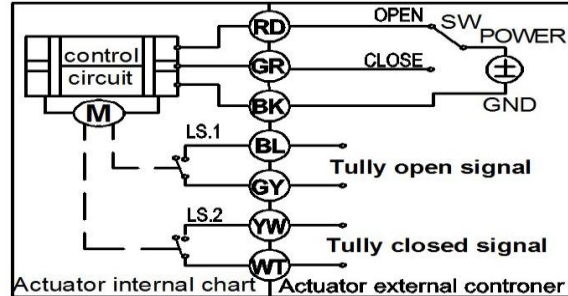

RD & GR connects to positive, BK connects to negative

When RD & SW are connected, the valve opens. Actuator switches off automatically when the ball valve is completely open.

When GR & SW are connected, the valve closes. Actuator switches off automatically when the ball valve is completely closed.

BL & GY connects to the valve's fully-open signal wiring.

YW & WT connects to the valve's fully-closed signal wiring.

W74 (7 Wire control with feedback signal)

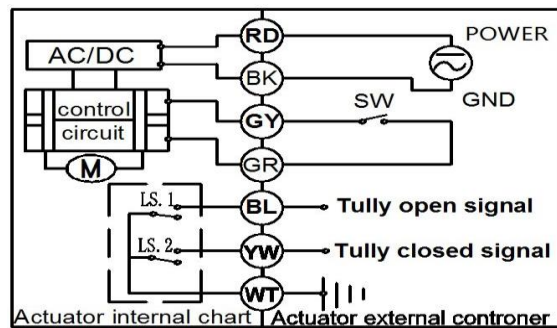

RD & BK are connected to the power, WT & YW are connected to the control wiring.

When the SW is closed, the valve will be open.

When SW is open, the valve will be closed.

BL & GY connects with the valve's fully-open signal wiring.

YW & WT connects with the valve's fully-closed signal wiring.

SW	- Switch
BL	- Blue
WT	- White
YW	- Yellow
RD	- Red
GR	- Green
BK	- Black
GY	- Gray

PNEUMATRON

www.pneumatron.co.za

sales01@pneumatron.co.za

Torque	Voltage	Wiring	A TYPE	C TYPE	B TYPE	
2 Nm	5V	W21	Y	Y	Y	
		W31/W72	Y	Y	Y	
		W51	Y	Y	Y	
	12/24V	W21	Y	Y	Y	
		W31/W72	Y	Y	Y	
		W51	Y	Y	Y	
	9-24VDC	W32/W71	Y	Y	Y	
	AC110-230V	W22			Y	
		W33/W73			Y	
		W41/W74			Y	
		W52			Y	
	AC/DC9-24V	W22			Y	Y
W33/W73		Y		Y	Y	
W52				Y	Y	
10 Nm	DC12V/24V	W21		Y		
		W33/W73		Y		
		W51		Y		
	AC/DC9-24V	W22			Y	
		W22			Y	
	AC110V-230V	W41/W74			Y	
W52				Y		

A TYPE: No Indicator, no Manual override.

B TYPE: With both Indicator and manual override.

C TYPE: With only Indicator.

2 Nm Actuator usually used for valves 1/8" to 1 1/2".

10 Nm Actuator usually used for valves 1 1/2" to 2".

PNEUMATRON

www.pneumatron.co.za

sales01@pneumatron.co.za

Dimensions

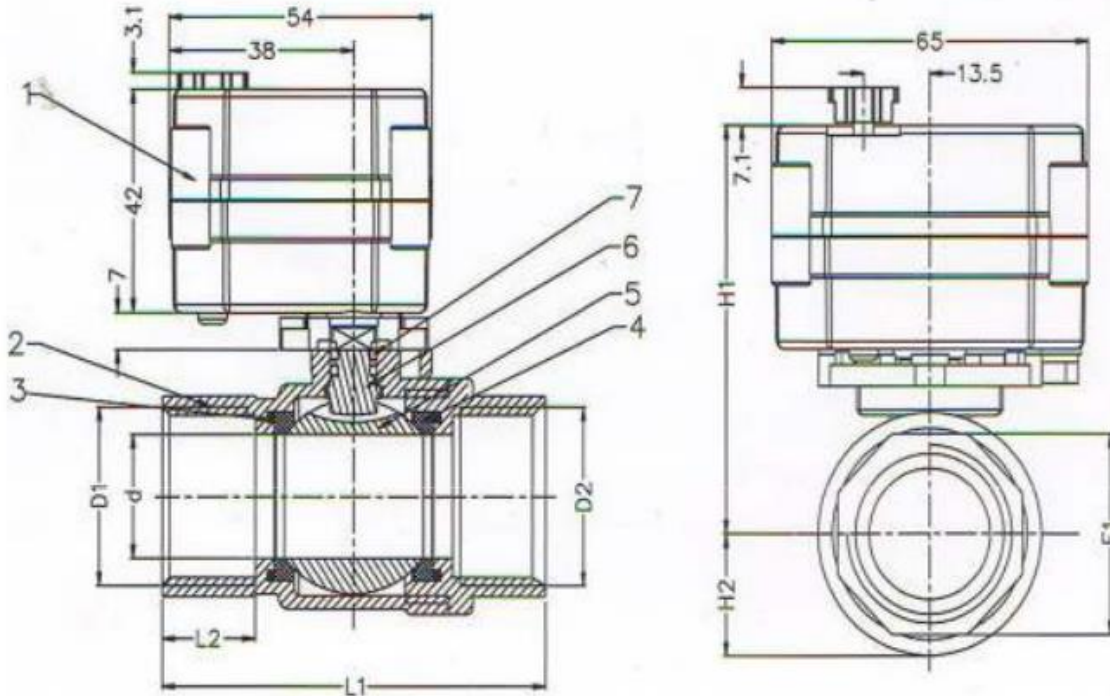

BODY DIMENSION CODE(Size in mm)						
Valve body	D1/D2	L1	L2	E1	H1	H2
PVX215WXXDX	1/2" (15mm)	63	14	25	70	17
PVX220WXXDX	3/4" (20mm)	72	17	31	74	20
PVX225WXXDX	1" (25mm)	81	18	38	82	24
PVX240WXXDX	1 1/2" (40mm)	115	25	52	130	36
PVX250WXXDX	2" (50mm)	130	25	66	138	45